



Sampling valve with membrane
for critical liquids
for process or storage tank
and sticky or solid bearing liquids

PEMC®



Optional:



Membrane:



Optional
membrane:



OVERVIEW:

The PEMC sampling valve is used to take a sample of liquid from a tank, whether clear, viscous, sticky or solid bearing, in order to carry out quality and/or bacterial controls. The PEMC valve is available in manual or automatic versions. Sealing is by a hung-type membrane on the drive head. The hygienic design with flush membrane (flared body) guarantees there is no retention zone (an ideal place for bacteria to develop) and is easy to clean.

The valve has a connection dedicated to the passage of CIP liquid thereby enabling the sampling chamber to be cleaned.

KEY BENEFITS:

- ▲ Specially designed for liquids with high viscosity or containing solid particles
- ▲ Hygienic design with flared body
- ▲ Sterilisation by CIP/SIP circulation
- ▲ Available in manual and automatic versions

APPLICATIONS:

- ▲ Sampling on tank of all types of liquids, including sticky and/or solid bearing ones
- ▲ Equipment especially suited to sampling of products subject to quality and/or bacterial controls

TECHNICAL SPECIFICATIONS:

One size: DN 15

Intake connection: To weld

Outlet connections: Smooth

CIP connection: Smooth

Service pressure: From 0 to 6 bar

Service temperature: From 1 °C to 120 °C

CIP/SIP support: Up to a temperature of 130 °C for 20 to 30 minutes

Materials:

- Parts in contact with the product: 1.4404 (316L) stainless steel
- Sealing: VMQ membrane (Silicone)
- Other parts: 1.4404 (316 L) or 1.4307 (304 L) stainless steel

DIMENSIONS EN MM :

SIZE	DN 15
A	79
B	59.5
C	163
D	181
E	17.2 x 1.6
F	136

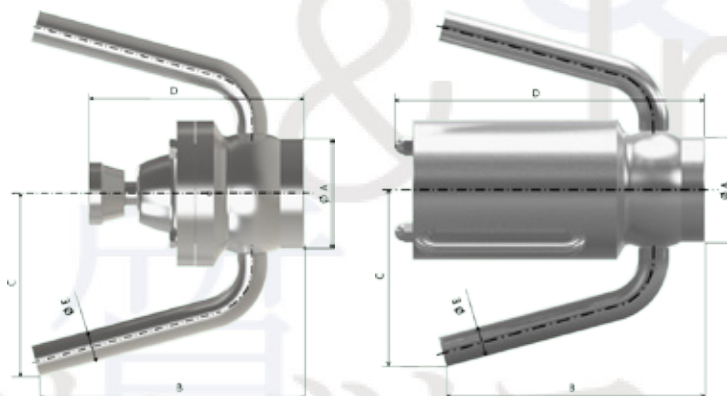

OPTIONS:

- Automatic version (single acting cylinder)
- Automatic version "ATEX 94/9/EC zones 1 & 2, gas and dust" certified
- Valve without CIP connection (if flame sterilisation)
- Other membranes: NBR (Nitrile rubber), EPDM (Ethylene Propylene Diene Monomer), FKM (Fluorocarbon rubber, eq. Viton®)
- Membrane USP Class VI compliant
- Special connections on request
- Customised equipment: please contact us

GUARANTEE:

12 months from the date of delivery (except in the case of special conditions)

COMPLIANCE:

- Ducting and tank accessories compliant with European PED 97/23/EC, §3.3
- Optional: Compliant "ATEX 94/9/EC, zones 1 & 2, gas & dust" for the automatic versions
- Membranes compliant with FDA CFR 21.177.2600 and 1935/2004/EC ruling
- Optional: Membrane USP Class VI compliant

SERVINOX follows the recommendations of international guidelines and standards relative to hygienic design and construction, in particular those of the EHEDG and 3-A.

Non contractual document and pictures, subject to change with no prior notice.

Only the commercial offer and the technical manual supplied with the equipment may be used for technical and legal purposes.

Servinox is an ISO 9001:2008 certified company

