

Zero-g Mixers

Features

Magnetically coupled mixer

No mechanical seals or stuffing boxes
Minimized cross-contamination risk

Bottom mounted

Low level mixing
No head space needed
Service friendly

Robust design

Ensured production reliability

Aseptic by design

Optimized for Cleaning and Sterilization
In-Place CIP/SIP
Aseptic Gap-Free Bearing Design

Mixing performance

Mixing characteristics optimal for Bio and
Pharma applications

Service friendly bearing design

Minimizing downtime during maintenance

Floating Zero-g Technology

Reducing shear
Minimizing particle shedding

Already commissioned vessel can easily be upgraded

Fits onto other brands of existing equipment

Scalable design

Reliable and easy scale up and scale down

Large Fluid Path

Reducing product shear



Metenova AB

Vädursgatan 6, SE-412 50, Sweden
www.metenova.com info@metenova.com
+46 (0) 31 335 95 00

DS-001 Rev D

Zero-g Mixer

Product Description

The Metenova, Zero-g, mixers offer a state of the art patent pending mixing solution for applications throughout the process line. The excellent aseptic design, materials complying with FDA regulations combined with the benefits of the new and innovative bearing design makes it perfect for use in the pharmaceutical and biotechnology industries



Type	RPM	Motor [kw] / [hp]	Volume range [liter] / [gallons]	Weight [kg] / [lbs]
ZG2	490	0.12 / 0.16	50 / 13	6.5 / 14
ZG3	490	0.30 / 0.40	250 / 66	8.5 / 19
ZG5	490	0.45 / 0.61	850 / 225	11.7 / 26
ZG6	490	0.66 / 0.90	1 200 / 317	16.8 / 37
ZG7	490	0.90 / 1.22	2 000 / 528	20.8 / 46
ZG8	343	2.5 / 3.40	5 000 / 1320	30.0 / 66
ZG9	245	2.5 / 3.40	10 000 / 2641	35.0 / 77
ZG10	245	3.5 / 4.75	20 000 / 5283	52.5 / 116

Metenova AB

Vädursgatan 6, SE-412 50, Sweden
www.metenova.com info@metenova.com
+46 (0) 31 335 95 00

Zero-g Mixer

Dimensions

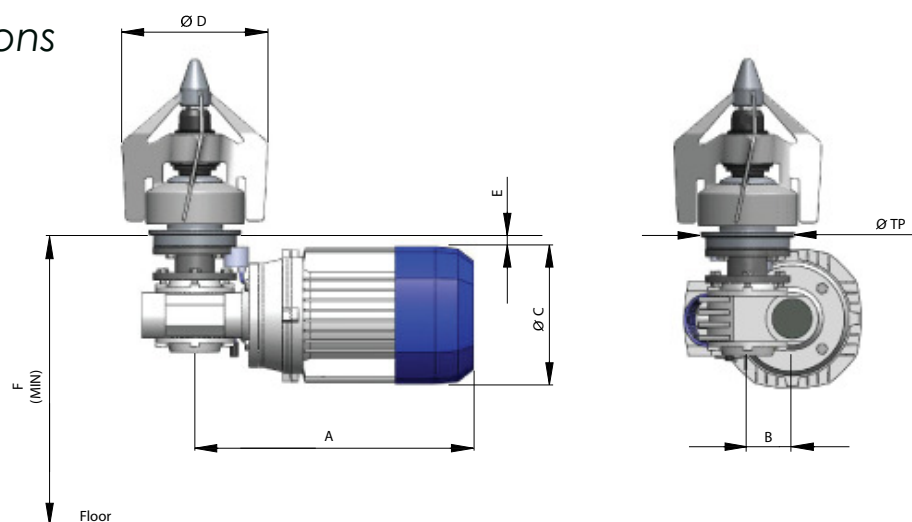

Item number	Item Description	A [mm] (Inch)	B [mm] (Inch)	ØC [mm] (Inch)	D [mm] (Inch)	E [mm] (Inch)	F [mm] (Inch)	ØTP [mm] (Inch)
ZG51501-00853	ZG2 Complete Mixer Welded	234 (9.21)	28 (1.10)	110 (4.33)	96 (3.78)	24 (0.95)	225 (8.86)	55 (2.17)
ZG12501-00981	ZG2 Complete Mixer Welded Extension 100 mm	234 (9.21)	28 (1.10)	110 (4.33)	96 (3.78)	124 (4.88)	325 (12.80)	55 (2.17)
ZG12501-00231	ZG3 Complete Mixer Welded	250 (9.84)	30 (1.18)	126 (4.96)	117 (4.61)	17 (0.67)	250 (9.84)	94 (3.70)
ZG12501-00277	ZG3 Complete Mixer Welded Extension 100 mm	250 (9.84)	30 (1.18)	126 (4.96)	117 (4.61)	117 (4.61)	350 (13.78)	94 (3.70)
ZG52501-00105	ZG5 Complete Mixer Welded	265 (10.43)	40 (1.57)	141 (5.55)	148 (5.83)	17 (0.67)	280 (11.02)	94 (3.70)
ZG52501-00278	ZG5 Complete Mixer Welded Extension 100 mm	265 (10.43)	40 (1.57)	141 (5.55)	148 (5.83)	117 (4.61)	380 (14.96)	94 (3.70)
ZG13501-00143	ZG6 Complete Mixer Welded	285 (11.22)	40 (1.57)	141 (5.55)	160 (6.30)	15 (0.59)	280 (11.02)	104 (4.09)
ZG13501-00279	ZG6 Complete Mixer Welded Extension 100 mm	285 (11.22)	40 (1.57)	141 (5.55)	160 (6.30)	115 (4.53)	380 (14.96)	104 (4.09)
ZG23501-00181	ZG7 Complete Mixer Welded	310 (12.20)	50 (1.97)	150 (5.91)	177 (6.97)	21 (0.83)	320 (12.60)	129.5 (5.10)
ZG23501-00280	ZG7 Complete Mixer Welded Extension 100 mm	310 (12.20)	50 (1.97)	150 (5.91)	177 (6.97)	121 (4.76)	420 (16.54)	129.5 (5.10)
ZG53501-00265	ZG8 Complete Mixer Welded	375 (14.76)	60 (2.36)	185 (7.28)	236 (9.29)	29 (1.14)	400 (15.75)	159.5 (6.28)
ZG53501-00281	ZG8 Complete Mixer Welded Extension 100 mm	375 (14.76)	60 (2.36)	185 (7.28)	236 (9.29)	129 (5.08)	500 (19.69)	159.5 (6.28)
ZG14501-00267	ZG9 Complete Mixer Welded	397 (15.63)	60 (2.36)	190 (7.48)	300 (11.91)	29 (-1.14)	400 (15.75)	199.5 (7.85)
ZG14501-00282	ZG9 Complete Mixer Welded Extension 100 mm	397 (15.63)	60 (2.36)	190 (7.48)	300 (11.91)	129 (5.08)	500 (19.69)	199.5 (7.85)
ZG24501-00269	ZG10 Complete Mixer Welded	432 (17.01)	70 (2.76)	202 (7.95)	350 (13.78)	28 (1.10)	400 (15.75)	229.5 (9.04)
ZG24501-00283	ZG10 Complete Mixer Welded Extension 100 mm	432 (17.01)	70 (2.76)	202 (7.95)	350 (13.78)	128 (5.04)	530 (20.87)	229.5 (9.04)

Notice: Information in this publication is subject to change without notice. The latest version will be available for download at www.metenova.com. The information in this document is believed to be complete and accurate at the time of publication. Metenova AB assumes no responsibility for any errors that may appear in this document.

Zero-g Mixer

Technical specifications

General information

Material wetted parts

Tank Plate:	Stainless Steel AISI 316L
Mixing Head:	Stainless Steel AISI 316L
Male Post:	Silicon Carbide (SiC)
O-Ring:	FDA & USP VI compliant EPDM
Female Sleeve:	Silicon Carbide (SiC)
O-Ring:	FDA & USP VI compliant EPDM

Surface Roughness: Ra ≤ 0.5 µm (20 µin)
(Optional Ra ≤ 0.25 µm (10 µin))

Surface Treatment: Manually polished or Manually polished and Electro polished. Non animal origin polishing compounds are used.

Operating Temp: 5°C - 150°C (41°F - 302°F)
(Optional 170°C, 338°F)

Environment Temp: 0°C - 40°C (32°F - 104°F)

Design Pressure Tank Plate: -1 - 7 barg (-14.7 - 103 psig)

pH Range: 1-14

Customized solutions: For customized solutions please contact Metenova AB

Motor Data:

Voltage:	230/ 400V AC - 50Hz 460/480V AC - 60 Hz
Degree of Protection:	IP 55
Certified:	CE/cCSAus, IEC, CEI/UNEL

Rotational sensor data:

Pulses/turn:	1
Wiring method:	3 Wire type
Sensor type:	PNP Current Sourcing
Operating voltage:	5-30V DC
Current consumption:	18mA@24V max.
Indicator:	Green LED
Temperature range:	-10°C – 70°C (14°F - 158°F)
Enclosure:	IP67

Packaging & Labeling:

For traceability purposes items are marked with item and id number. They are individually packed in sealed and labeled boxes.

Quality Control: Metenova Quality Assurance system ensure the quality and traceability at all stages of the process.

Options: Non-standard Metenova Mixer Options and other material are available, please contact Metenova for further information.

Mixer Accessories:

- Control Cabinet
- Mounting tool female sleeve
- Mounting tool male post
- Lifting tool mixing head
- Welding tools Tankplate

Mixer Spare Parts:

- O-rings
- Male Post
- Female Sleeve
- Mix Head
- Drive Unit